

STARGATE S111

From Aquarama creativity and innovation
the future takes shape



AQUARAMA®
CAR WASH SYSTEM

STARGATE S111

- Innovative technological solutions
- Technology built to last
- High quality washing



MORE SPACE FOR BIG VEHICLES

WIDE VEHICLE PASSAGE CAN BE INSTALLED IN SMALL WASH BAYS.

Washing width

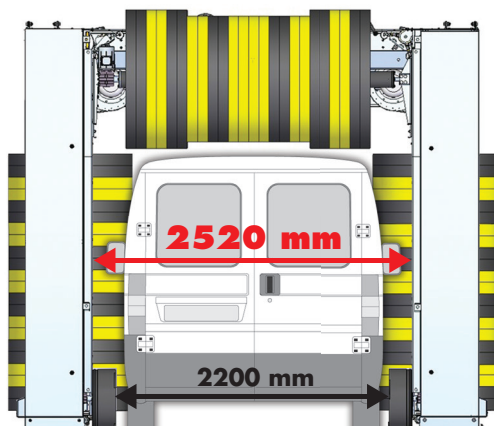

Available washing heights

2500 mm

2300 mm

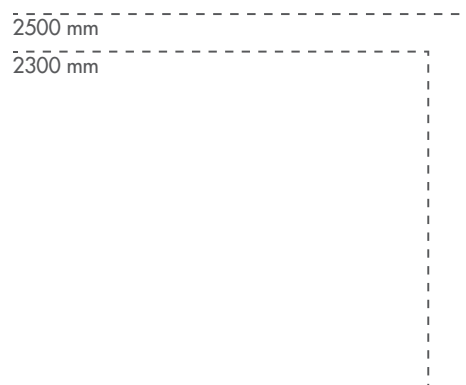

THE INTERMEDIATE MOBILE ARCH: COMPLETE WASH IN LESS PASSAGES

ADVANTAGES

Adequate and programmable reaction times for detergents and wax applications.

Two complete passages with brushes for extremely high quality finish.

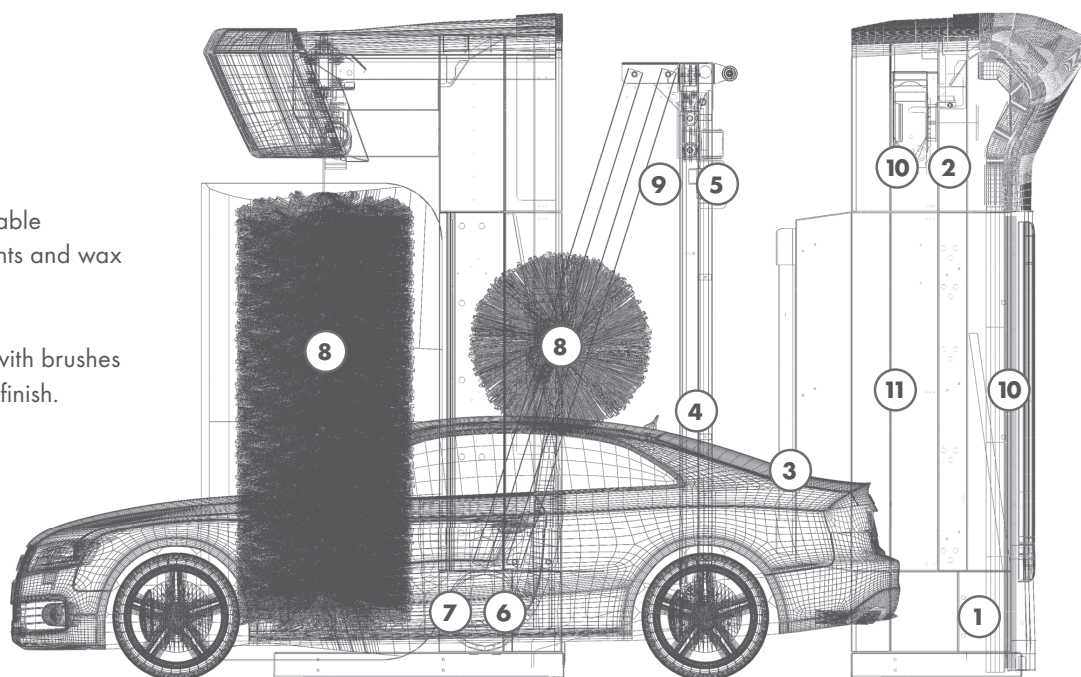

IN LESS THAN FOUR MINUTES...

Forward pass

- 1 - Rims
- 2 - Insects
- 3 - Active foam pre-wash
- 4 - High pressure lateral jets
- 5 - Contour following horizontal HP
- 6 - Rotating HP jets for wheels and sills
- 7 - Wheel washer
- 8 - Brushes with shampoo

Return pass

- 8 - Brushes and rinse
- 9 - Contour following wax application
- 10 - Drying

IN LESS THAN SIX MINUTES...

Forward pass

- 1 - Rims
- 2 - Insects
- 3 - Active foam pre-wash
- 4 - High pressure lateral jets
- 5 - Contour following horizontal HP
- 6 - Rotating HP jets for wheels and sills
- 7 - Wheel washer
- 8 - Brushes with shampoo

Return pass

- 8 - Brushes and rinse
- 10 - Fast drying

Forward pass

- 11 - Polish application
- 8 - Polishing with brushes

Return pass

- 8 - Brushes and rinse
- 9 - Contour following wax application
- 10 - Drying

PATENTED
SYSTEM



STARGATE *S111*

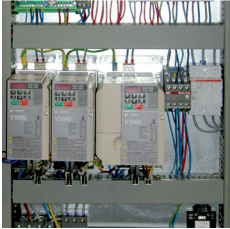

SEVEN FREQUENCY CONVERTERS

The seven frequency converters deliver a rapid smooth pass, for a precise wash on every part of the vehicle.

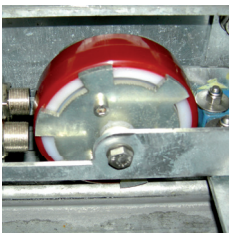

DRIVE AND LIFT SENSOR

Measurement movements with two sensors for maximum precision and reliability.

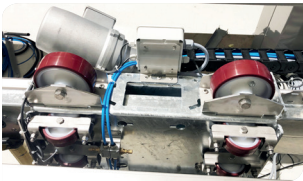

LOW MAINTENANCE THANKS TO SELF-LUBRICATING MATERIALS

Innovative materials for silent movements requiring no lubrication or maintenance.



PERFECT DRYING IN ONLY ONE PASSAGE

Stainless steel horizontal blade following the vehicle profile, tilting in 3 positions. Inclined side vents. Four electric blowers 5,5 kW/each.



INTERMEDIATE GANTRY

Third mobile gantry emerging from the first gantry on an extension system. The intermediate gantry incorporates high pressure and wax application features.



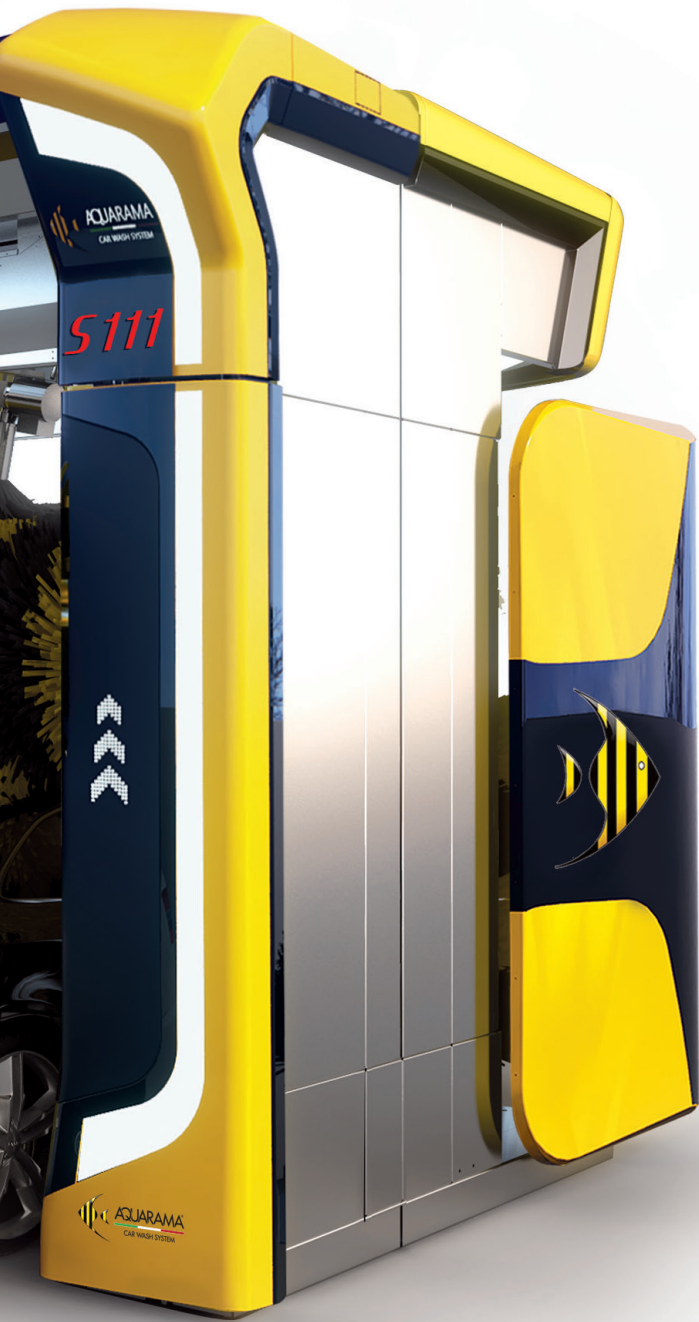

The gantry model shown is equipped with optional

SECURITY

Lifting belt loosening alarm. Blade anti-fall locking system on drying.

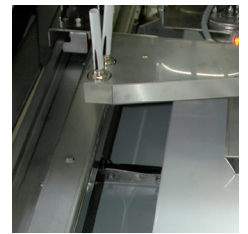

HIGH PRESSURE WITH TURBO NOZZLES

Consisting of 13 stainless steel 30 ° rotating heads, 7 of which can be swiveled to 3 positions and fixed on the side parts.



TILT AND LOCK VERTICAL BRUSHES

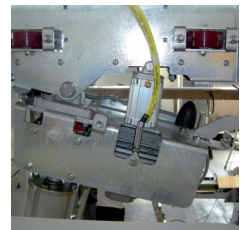

WAX APPLICATION

The wax is applied using a contour following wax arch and laterally delivered by nozzles positioned close to the vehicle sides, for a perfect water-repellent effect.



STAINLESS STEEL WHEEL WASHER

The inversion of rotation and inclination of the brush allows thorough cleaning of the circles of various sizes.



COLOURS AVAILABLE



LED TRAFFIC LIGHT INTEGRATED IN THE GANTRY LEG

Wide traffic light with LEDs, sliding display. Perfect also in bright light conditions.





VERSION STARLIGHT

The bright white led bar lights up the darkness for an optimal view even during evening washes or in shaded areas.
The new restyling focuses on aesthetics without forgetting functionality.

WAVETECH BRUSHES



- GREATER WASHING POWER
- DELICACY AND EFFICIENCY ON BODYWORK FOR GREAT RESULTS
- WASH UNIFORMITY
- AESTHETICS/ATTRACTIVE MOVEMENT

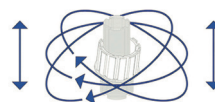

Thanks to the oscillating movement, the exclusive WaveTech system simulates manual washing, guaranteeing optimal results. The bristles rub the bodywork accurately and uniformly avoiding washing GAP. This movement also generates a self-cleaning effect on the brush itself and faster drying.

STARGUIDE

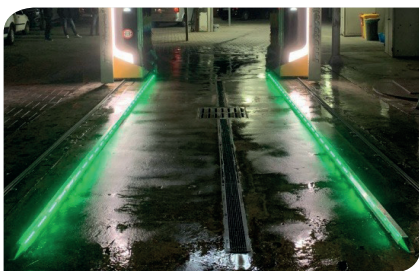

WHEELS GUIDE TUBES

Stainless steel wheels guide tubes available in the following sizes: 6, 9, 12 mt. The LEDs on the wheel guide tubes, coordinated with the traffic lights (green-forward, red-stop, yellow-back), facilitate handling during the vehicle positioning phase. Multicolor LEDs accompany the entire wash cycle.

PHOTOCELLS' BARRIER (Optional)

Thanks to the photocells' barrier it is possible to detect any vehicle's shape, optimizing the horizontal brush contact and the drying blade pass.



High precision of detection

Automatic detection of particular shapes
(I. E. Pickup, Skibox, Lightbars, etc.)

High Speed Detection

First pass up 20 m/min.

High Smoothness of Functioning

Drying blade - Horizontal brush
Horizontal High Pressure.



HIGH PRESSURE SYSTEM



WHEELS

Tilting wheel washer with fully integrated rotating high pressure, for a thorough cleaning of rims, wheel arches and sills.



FIXED LATERAL

Located on intermediate mobile arch. Advanced position for a perfect pre-wash.



HORIZONTAL CONTOUR FOLLOWING

Located on intermediate mobile arch. 3 positions tilt optimizing water impact on vehicle's body. Advanced position for a perfect pre-wash.

HIGH PRESSURE PUMPS SYSTEM

Choices of 126 or 168 liters high pressure pumps system, for a powerful pre-wash. Available in insulated outdoor cabinet or in frame for technical room.



CABINET

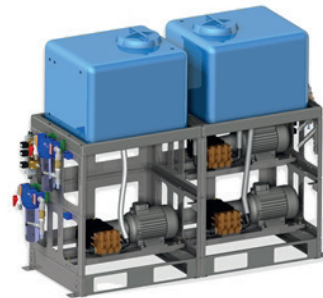

FRAME

SELF SERVICE SYSTEM – CONTROL UNITS



It accepts



Touch



Smart Coin Card with a value or a program



Banknotes



Coins and/or tokens



Certified payment system for self-service banking transactions with bank card and Smartphone.



It delivers



Receipt (no fiscal)



Smart Coin Card
Self Service Top Line only



Coins
and/or tokens
2 hoppers

The operator can configure each passage to create personalized programs.

Possibility for the customer to add any optionals to the selected basic wash.

STARGATE S111

Structure

- Hot dip galvanized and painted steel structure
- ABS plastic claddings (optional)
- Direct gantry drive with frequency converter
- High resistance rivets "aeronautic" type
- Stainless steel bolts

Vertical brushes

- Hot dip galvanized steel single cross beam
- Electrical positioning drive with frequency converter
- Double cross over on front and back of the vehicle
- Double inclination and locking by cylinder
- Electronic power control

Horizontal brush

- Electrical uplift with frequency converter
- Electronic power control
- Stainless steel sliding guides

Intermediate mobile arch

- Automatic movement on an extension system
- Stainless steel horizontal blade following the vehicle profile for wax application. 3 positions tilting for horizontal high pressure (optional)
- Electrical uplift with frequency converter
- Stainless steel sliding guides
- Bracket for fixed sides high pressure

Drying

- 3 positions tilting stainless steel horizontal blade following the vehicle profile
- Electrical uplift with frequency converter
- Stainless steel sliding guides
- Side drying 2 electric blowers with inclined side vents
- Security device anti-crush

Standard equipment

- Hydraulic system with dedicated solenoid valves and piping
- Shampoo dosing pump
- Wax dosing pump
- 2 single festoon supply systems (wall hanging)
- Control panel in dedicated wall box
- Fully integrated preset self-service kit

AQUARAMA Srl
Località Piano, 38 - 12060 Novello (CN) - ITALIA
Tel. +39 0173 776822 - Fax +39 0173 792501 - info@aquarama.it

Follow us on



Advanced technology for a lasting success and reliability

TECHNICAL FEATURES

Dimensions Stargate S111 (in millimetres)

Washing height	2.300	2.500
Machine height	*3.300 (3.180)	*3.500 (3.380)
Machine width	*3.715 (3.600)	
Washing width	2.520	
Machine depth	*3.200 (2.500)	
Machine weight	1.900 + 1.700	2.000 + 1800
Distance between rails	3.000 (2.800 upon demand)	
Rails length	12.000	

*Max dimensions with ABS claddings

() Dimensions with standard aluminium cladding

Hall or washing bay dimensions for vehicles 5 meters long (in millimetres)

Height	*3.400 (3.300)	*3.600 (3.500)
Width	**4.100 (4.600)	
Length	*11.700 • * **11.450 • (11.300) • ** (10.750)	

*Dimensions with ABS claddings

**With optional safety anti-crush device.

() Dimensions with standard aluminium cladding

Technical data sheet

Drive speed	m/min	0-22
Water pressure	Bar/l	3-5
Air pressure	Bar	8
Voltage	V/Hz	400 3/N/PE 50
Total power	kW	30
Control voltage	V	24
Drying power	kW	4x5,5

High pressure pumps (optional)

Water high pressure	Bar	80
---------------------	-----	----

Data are merely indicative and are not binding.



Certificato
Nr 50 100 7925



AQUARAMA®

CAR WASH SYSTEM

www.aquarama.it